

Výpočet vnitřních sil na složené soustavě

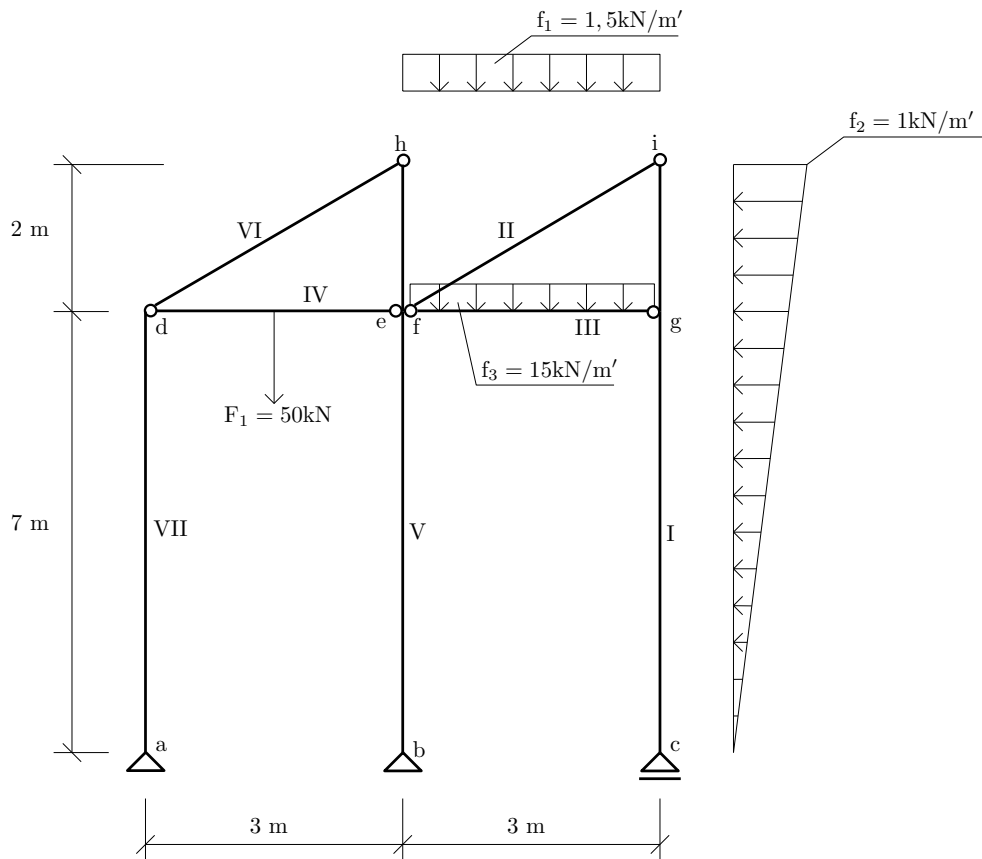

Obrázek 1: Schéma průřezu.

Úkol: Vypočítejte reakce a nakreslete průběh normálové síly N , posouvající síly V a ohybového momentu M na celé konstrukci.

Řešení:

1) Výpočet reakcí a vnitřních sil:

deska č.I

$$\circlearrowleft i : -Q_2 \cdot 3 + G_x \cdot 2 = 0 \Rightarrow \underline{G_x = 6,75\text{ kN}} \quad (1)$$

$$\rightarrow : I_x + G_x - Q_2 = 0 \Rightarrow \underline{I_x = -2,25\text{ kN}} \quad (2)$$

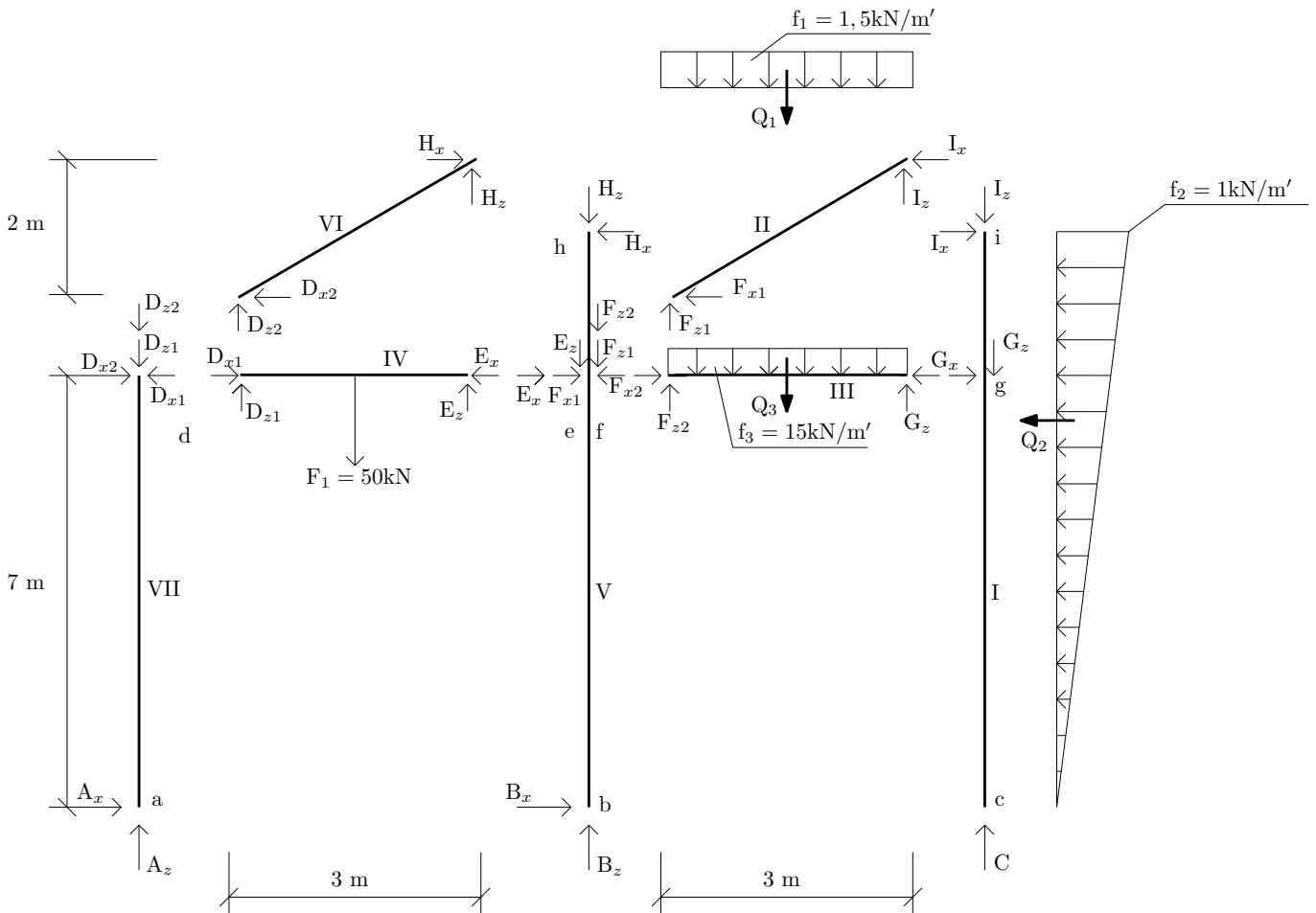

Obrázek 2: Rozdělení na jednotlivé desky.

deska č.II

$$\circlearrowleft f : -Q_1 \cdot 1,5 + I_z \cdot 3 + I_x \cdot 2 = 0 \Rightarrow \underline{I_z = 3,75 \text{ kN}} \quad (3)$$

$$\uparrow : F_{z1} + I_z - Q_1 = 0 \Rightarrow \underline{F_{z1} = 0,75 \text{ kN}} \quad (4)$$

$$\rightarrow : -F_{x1} - I_x = 0 \Rightarrow \underline{F_{x1} = 2,25 \text{ kN}} \quad (5)$$

deska č.III

$$\circlearrowleft f : -Q_3 \cdot 1,5 + G_z \cdot 3 = 0 \Rightarrow \underline{G_z = 22,5 \text{ kN}} \quad (6)$$

$$\downarrow : Q_3 - G_z - F_{z2} = 0 \Rightarrow \underline{F_{z2} = 22,5 \text{ kN}} \quad (7)$$

$$\rightarrow : F_{x2} - G_x = 0 \Rightarrow \underline{F_{x2} = 6,75 \text{ kN}} \quad (8)$$

deska č.I

$$\downarrow : I_z + G_z - C = 0 \Rightarrow \underline{C = 26,25 \text{ kN}} \quad (9)$$

celkem:

$$\circlearrowleft b : -A_z \cdot 3 + F_1 \cdot 1,5 - Q_1 \cdot 1,5 - Q_3 \cdot 1,5 + Q_2 \cdot 6 + C \cdot 3 = 0 \Rightarrow \underline{A_z = 35,5 \text{ kN}} \quad (10)$$

$$\downarrow : -A_z + F_1 + Q_1 + Q_3 - C - B_z = 0 \Rightarrow \underline{B_z = 37,75 \text{ kN}} \quad (11)$$

deska č.IV

$$\circlearrowleft d : E_z \cdot 3 - F_1 \cdot 1,5 = 0 \Rightarrow \underline{E_z = 25 \text{ kN}} \quad (12)$$

$$\uparrow : D_{z1} - F_1 + E_z = 0 \Rightarrow \underline{D_{z1} = 25 \text{ kN}} \quad (13)$$

deska č.V

$$\uparrow : B_z - E_{z1} - F_{z2} - F_{z1} - H_z = 0 \Rightarrow \underline{H_z = -10,5 \text{ kN}} \quad (14)$$

deska č.VI

$$\downarrow : -H_z - D_{z2} = 0 \Rightarrow \underline{D_{z2} = 10,5 \text{ kN}} \quad (15)$$

$$\circlearrowleft h : H_z \cdot 3 - D_{x2} \cdot 2 = 0 \Rightarrow \underline{D_{x2} = -15,75 \text{ kN}} \quad (16)$$

$$\rightarrow : -D_{x2} + H_x = 0 \Rightarrow \underline{H_x = -15,75 \text{ kN}} \quad (17)$$

deska č.V

$$\circlearrowleft b : F_{x2} \cdot 7 - F_{x1} \cdot 7 - E_x \cdot 7 + H_x \cdot 9 = 0 \Rightarrow \underline{E_x = -15,75 \text{ kN}} \quad (18)$$

$$\rightarrow : -H_x + F_{x1} + E_x - F_{x2} + B_x = 0 \Rightarrow \underline{B_x = 4,5 \text{ kN}} \quad (19)$$

deska č.IV

$$\rightarrow : D_{x1} - E_x = 0 \Rightarrow \underline{D_{x1} = -15,75 \text{ kN}} \quad (20)$$

deska č.VII

$$\rightarrow : -D_{x1} + D_{x2} + A_x = 0 \Rightarrow \underline{A_x = 0 \text{ kN}} \quad (21)$$

2) Analytické vyjádření průběhu vnitřních sil:

interval (a, d):

$$N^{ad} = -A_z \Rightarrow \underline{N^{ad} = -35,5 \text{ kN}} \quad (22)$$

$$N^{da} = N^{ad} \Rightarrow \underline{N^{da} = -35,5 \text{ kN}} \quad (23)$$

$$V^{ad} = \underline{0 \text{ kN}} \quad (24)$$

$$V^{da} = \underline{0 \text{ kN}} \quad (25)$$

$$M^a = \underline{0 \text{ kNm}} \quad (26)$$

$$M^d = \underline{0 \text{ kNm}} \quad (27)$$

interval (b, e):

$$N^{be} = -B_z \Rightarrow \underline{N^{be} = -37,75 \text{ kN}} \quad (28)$$

$$N^{eb} = N^{be} \Rightarrow \underline{N^{eb} = -37,75 \text{ kN}} \quad (29)$$

$$V^{be} = -B_x \Rightarrow \underline{V^{be} = -4,5 \text{ kN}} \quad (30)$$

$$V^{eb} = V^{be} \Rightarrow \underline{V^{eb} = -4,5 \text{ kN}} \quad (31)$$

$$M^b = \underline{0 \text{ kNm}} \quad (32)$$

$$M^{eb} = B_x \cdot 7 \Rightarrow \underline{M^{eb} = 31,5 \text{ kNm}} \quad (33)$$

interval (e, h):

$$N^{eh} = -B_z + F_{z1} + F_{z2} + E_z \Rightarrow \underline{N^{eh} = 10,5 \text{ kN}} \quad (34)$$

$$N^{he} = N^{eh} \Rightarrow \underline{N^{he} = 10,5 \text{ kN}} \quad (35)$$

$$V^{eh} = -B_x - E_x - F_{x1} + F_{x2} \Rightarrow \underline{V^{eh} = 15,75 \text{ kN}} \quad (36)$$

$$V^{he} = V^{eh} \Rightarrow \underline{V^{he} = 15,75 \text{ kN}} \quad (37)$$

$$M^{eh} = M^{eb} \Rightarrow \underline{M^{eh} = 31,5 \text{ kNm}} \quad (38)$$

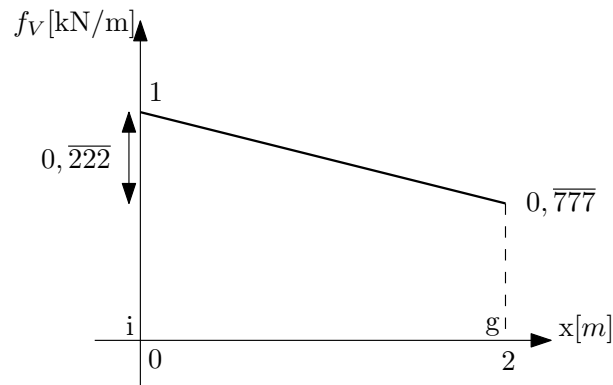

Obrázek 3: Průběh zatížení.

interval (i, g):

$$N^{ig} = -I_z \Rightarrow \underline{N^{ig} = -3,75 \text{ kN}} \quad (39)$$

$$N^{gi} = N^{ig} \Rightarrow \underline{N^{gi} = -3,75 \text{ kN}} \quad (40)$$

$$f_V(x) = -\frac{0,222}{2} \cdot x + 1$$

$$V(x) = -\int f_V(x) dx = \frac{0,222}{4} \cdot x^2 - 1 \cdot x - 2,25$$

$$V(0) = \frac{0,222}{4} \cdot 0^2 - 1 \cdot 0 - 2,25 = \underline{-2,25 \text{ kN}}$$

$$V(2) = \frac{0,222}{4} \cdot 2^2 - 1 \cdot 2 - 2,25 = \underline{-4,028 \text{ kN}}$$

$$V(x) = 0 \Rightarrow \frac{0,222}{4} \cdot x^2 - 1 \cdot x - 2,25 = 0 \Rightarrow x_{\max} = \underline{15,36; 2,636}$$

$$V^{ig} = V(0) \Rightarrow \underline{V^{ig} = -2,25 \text{ kN}} \quad (41)$$

$$V^{gi} = V(2) \Rightarrow \underline{V^{gi} = -4,028 \text{ kN}} \quad (42)$$

$$M(x) = \int V(x) dx = \frac{0,222}{12} \cdot x^3 - \frac{1}{2} \cdot x^2 - 2,25 \cdot x$$

$$M(2) = \frac{0,222}{12} \cdot 2^3 - \frac{1}{2} \cdot 2^2 - 2,25 \cdot 2 = \underline{-6,35 \text{ kNm}}$$

$$M^{gi} = M(2) \Rightarrow \underline{M^{gi} = -6,35 \text{ kNm}} \quad (43)$$

$$M^i = M(0) \Rightarrow \underline{M^i = 0 \text{ kNm}} \quad (44)$$

interval (g, c):

$$N^{gc} = -I_z - G_z \Rightarrow \underline{N^{gc} = -26,25 \text{ kN}} \quad (45)$$

$$N^{cg} = N^{gc} \Rightarrow \underline{N^{cg} = -26,25 \text{ kN}} \quad (46)$$

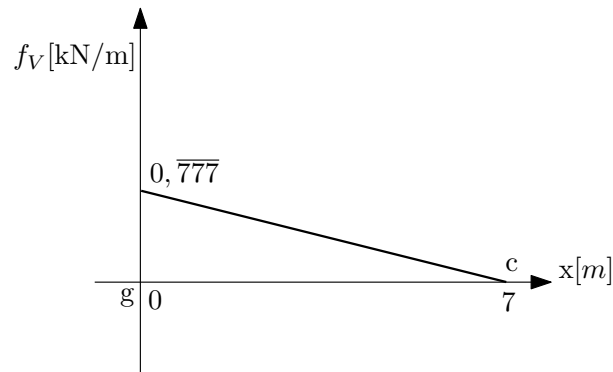

Obrázek 4: Průběh zatížení.

$$f_V(x) = -\frac{0,777}{7} \cdot x + 0,777$$

$$V(x) = -\int f_V(x)dx = \frac{0,777}{14} \cdot x^2 - 0,777 \cdot x + 6,75 - 4,028$$

$$V(0) = \frac{0,777}{14} \cdot 0^2 - 0,777 \cdot 0 + 6,75 - 4,028 = \underline{2,722 \text{ kN}}$$

$$V(7) = \frac{0,777}{14} \cdot 7^2 - 0,777 \cdot 7 + 6,75 - 4,028 = \underline{0 \text{ kN}}$$

$$V(x) = 0 \Rightarrow \frac{0,777}{14} \cdot x^2 - 0,777 \cdot x + 6,75 - 4,028 = 0 \Rightarrow x_{\max} = \underline{7}$$

$$V^{gc} = V(0) \Rightarrow \underline{V^{gc} = 2,722 \text{ kN}} \quad (47)$$

$$V^{cg} = V(7) \Rightarrow \underline{V^{cg} = 0 \text{ kN}} \quad (48)$$

$$M(x) = \int V(x)dx = \frac{0,777}{42} \cdot x^3 - \frac{0,777}{2} \cdot x^2 + 2,722 \cdot x - 6,35$$

$$M(7) = \frac{0,777}{42} \cdot 7^3 - \frac{0,777}{2} \cdot 7^2 + 2,722 \cdot 7 - 6,35 = \underline{0 \text{ kNm}}$$

$$M^{gc} = M_{gi} \Rightarrow \underline{M^{gc} = -6,35 \text{ kNm}} \quad (49)$$

$$M^c = M(7) \Rightarrow \underline{M^c = 0 \text{ kNm}} \quad (50)$$

interval (d, e):

$$N^{de} = -D_{x1} \Rightarrow \underline{N^{de} = 15,75 \text{ kN}} \quad (51)$$

$$N^{ed} = N^{de} \Rightarrow \underline{N^{ed} = 15,75 \text{ kN}} \quad (52)$$

$$V^{de} = D_{z1} \Rightarrow \underline{V^{de} = 25 \text{ kN}} \quad (53)$$

$$V^{ed} = D_{z1} - F_1 \Rightarrow \underline{V^{ed} = -25 \text{ kN}} \quad (54)$$

$$M_{\max} = D_{z1} \cdot 1,5 \Rightarrow \underline{M_{\max} = 37,5 \text{ kNm}} \quad (55)$$

interval (f, g):

$$N^{fg} = -F_{x2} \Rightarrow \underline{N^{fg} = -6,75 \text{ kN}} \quad (56)$$

$$N^{gf} = N^{fg} \Rightarrow \underline{N^{gf} = -6,75 \text{ kN}} \quad (57)$$

$$V^{fg} = F_{z2} \Rightarrow \underline{V^{fg} = 22,5 \text{ kN}} \quad (58)$$

$$V^{gf} = F_{z2} - f_3 \cdot 3 \Rightarrow \underline{V^{gf} = -22,5 \text{ kN}} \quad (59)$$

$$M^{fg} = \underline{0 \text{ kNm}} \quad (60)$$

$$M^{gf} = \underline{0 \text{ kNm}} \quad (61)$$

$$M \text{ max} = F_{z2} \cdot 1,5 - f_3 \cdot 1,5 \cdot 0,75 \Rightarrow \underline{M \text{ max} = 16,875 \text{ kNm}} \quad (62)$$

interval (d, h):

Rozklad sil :

$$D_{z2V} = H_{zV} = D_{z2} \cdot \cos \alpha = 8,7365 \text{ kN/m}' \quad (63)$$

$$D_{x2N} = H_{xN} = D_{x2} \cdot \cos \alpha = -13,10479 \text{ kN/m}' \quad (64)$$

$$D_{z2N} = H_{zN} = D_{z2} \cdot \sin \alpha = 5,82435 \text{ kN} \quad (65)$$

$$D_{x2V} = H_{xV} = D_{x2} \cdot \sin \alpha = -8,7365 \text{ kN} \quad (66)$$

$$N^{dh} = -D_{z2N} + D_{x2N} \Rightarrow \underline{N^{dh} = -18,929 \text{ kN}} \quad (67)$$

$$N^{hd} = N^{dh} \Rightarrow \underline{N^{hd} = -18,929 \text{ kN}} \quad (68)$$

$$V^{dh} = D_{z2V} + D_{x2V} \Rightarrow \underline{V^{dh} = 0 \text{ kN}} \quad (69)$$

$$V^{hd} = V^{dh} \Rightarrow \underline{V^{hd} = 0 \text{ kN}} \quad (70)$$

$$M^h = \underline{0 \text{ kNm}} \quad (71)$$

interval (f, i):

Rozklad sil :

$$F_{z1V} = F_{z1} \cdot \cos \alpha = 0,624 \text{ kN/m}' \quad (72)$$

$$F_{x1N} = I_{xN} = F_{x1} \cdot \cos \alpha = 1,872 \text{ kN/m}' \quad (73)$$

$$F_{z1N} = F_{z1} \cdot \sin \alpha = 0,416 \text{ kN} \quad (74)$$

$$F_{x1V} = I_{xV} = F_{x1} \cdot \sin \alpha = 1,248 \text{ kN} \quad (75)$$

$$I_{zV} = I_z \cdot \cos \alpha = 3,12 \text{ kN/m}' \quad (76)$$

$$I_{zN} = I_z \cdot \sin \alpha = 2,08 \text{ kN/m}' \quad (77)$$

$$f'_1 = \frac{f_1 \cdot 3}{3,6} = 1,25 \text{ kN/m}' \quad (78)$$

$$f_{1V} = f'_1 \cdot \cos \alpha = 1,04 \text{ kN/m}' \quad (79)$$

$$f_{1N} = f'_1 \cdot \sin \alpha = 0,6934 \text{ kN/m}' \quad (80)$$

$$N^{fi} = -F_{z1N} + F_{x1N} \Rightarrow \underline{N^{fi} = 1,456 \text{ kN}} \quad (81)$$

$$N^{if} = I_{zN} + I_{xN} \Rightarrow \underline{N^{if} = 3,952 \text{ kN}} \quad (82)$$

$$V^{fi} = F_{z1V} + F_{x1V} \Rightarrow \underline{V^{fi} = 1,872 \text{ kN}} \quad (83)$$

$$V^{if} = -I_{zV} + I_{xV} \Rightarrow \underline{V^{if} = -1,872 \text{ kN}} \quad (84)$$

$$M^{fi} = \underline{0 \text{ kNm}} \quad (85)$$

$$M^{if} = \underline{0 \text{ kNm}} \quad (86)$$

$$M \text{ max} = -f_{1V} \cdot 1,8 \cdot 0,9 + F_{z1V} \cdot 1,8 + F_{x1V} \cdot 1,8 \Rightarrow \underline{M \text{ max} = 1,648 \text{ kNm}} \quad (87)$$

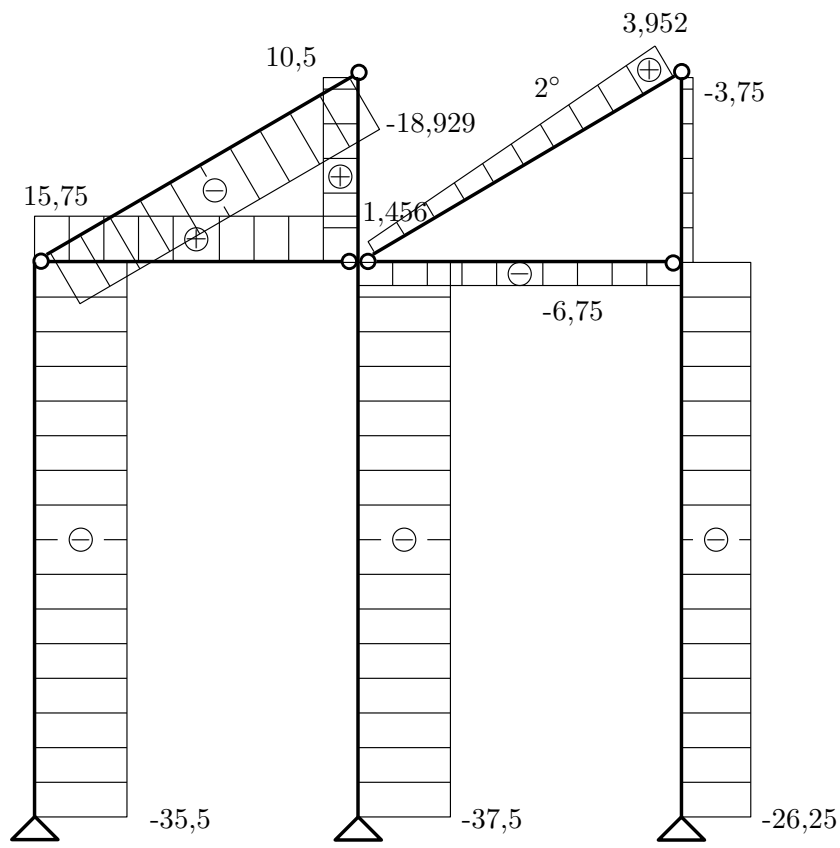

Obrázek 5: Normálové síly.

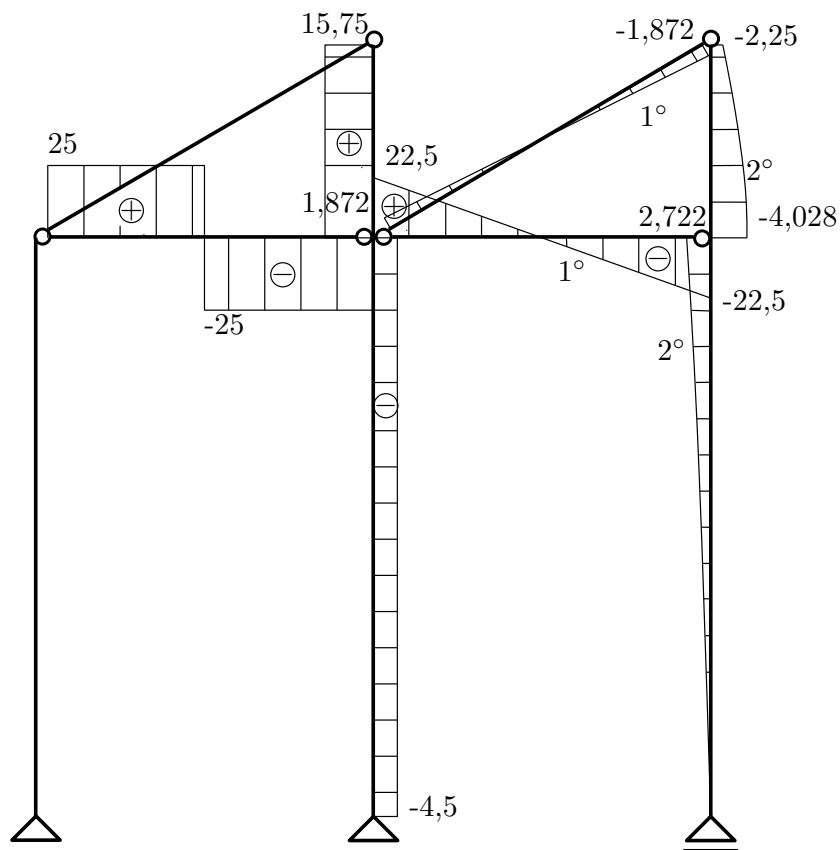

Obrázek 6: Posouvající síly.

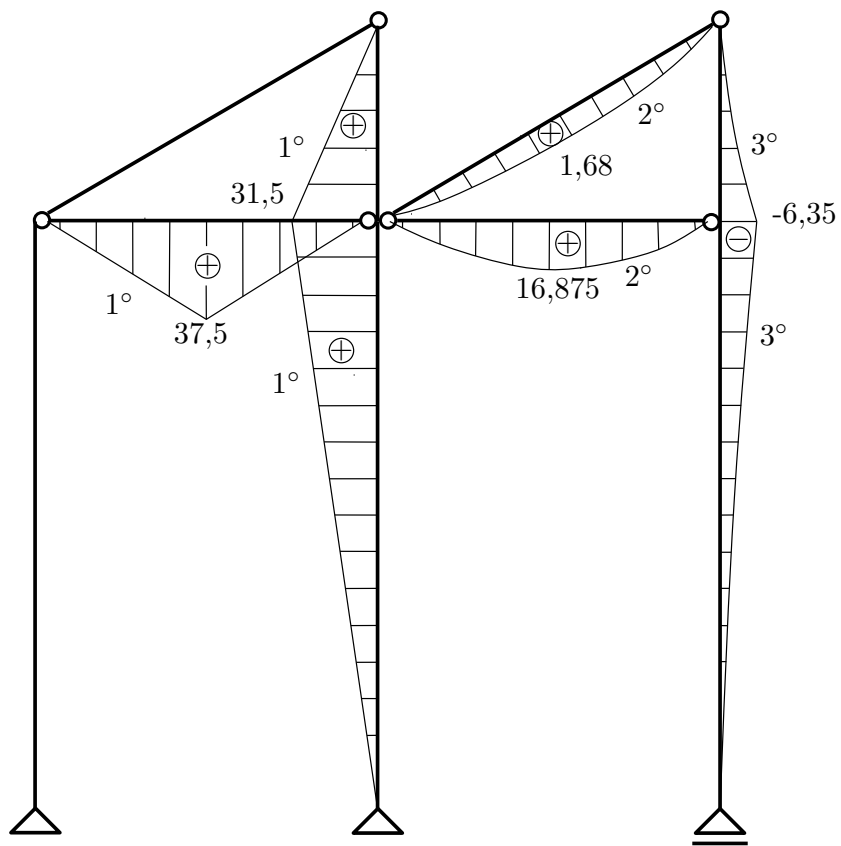

Obrázek 7: Ohybové momenty.